

# Kebu Polycor Tape GW/KF DATA SHEET

- Hot-applied corrosion protection tape
- Modified polymer and bitumen material
- Max. operating temperature 50 °C
- 4-layered application



**Kebu Polycor Tape GW/KF** is a hot applied corrosion protection tape made out of modified polymer and bitumen. It's suitable for the protection of ground to air transitions of pipes, T-pieces and complicated molded parts.

**Kebu Polycor Tape GW/KF** is designed for a maximum operating temperature of 50 °C.

The embedded carriers are a glass fabric (about 200 g/m<sup>2</sup>) and a hostaphan film. They provide high elasticity.

Together with the liquid adhesive **Polycor-Primer KIII** it forms an effective corrosion protection system for steel pipes and molded parts.

## STRUCTURE

- Polycor-Primer KIII
- 4 layer Polycor-Tape GW/KF

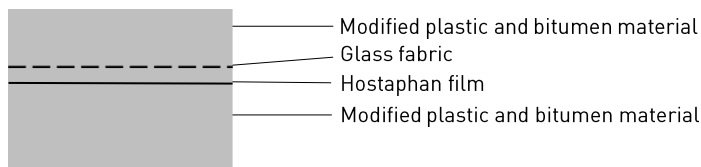

## COATING

The **Kebu Polycor Tape GW/KF** is compatible with factory coatings of PE, PP, epoxy resin, PU and bitumen. It can be used for Field Joint Coating, Coating Rehabilitation and Coating Repair.

## FORMS OF DELIVERY

Polycor-Primer KIII in Containers of 1 l and 5 l

	Length of roll [m]	Width of roll [mm]
Kebu Polycor Tape GW/KF	10	100
	10	150
	10	200
	10	250

## PROPERTIES

Property	Unit	Typical values
Impact resistance	J	≥ 8
Indentation resistance	mm	≥ 0,6
Residual layer thickness at 23 °C	mm	≥ 0,6
Maximal tensile force	N / 50 mm	≥ 1500
Thickness	mm	≥ 4
Number of layers	-	4

Preserving values.

ORIGINAL  
**kebu**®

# Kebu Polycor Tape GW/KF DATA SHEET

## APPLICATION

The area to be coated is 300 mm in the air section and 600 mm in the ground section, including 100 mm of the factory coating.

Wire brush the steel surface thoroughly to remove rust, dirt and residuals of the ultrasonic inspection coupling agent of temporary and edge protection respectively.

When there is a renovation, the old coating must be removed entirely and the surface has to be prepared by mechanical means using qualified equipment e.g. grid blasting in accordance to DIN EN ISO 12944-4 Sa 2 ½.

On steel pipes with a three-layer factory polyolefin coating, the layers of epoxy resin and bonding adhesive on the pipe surface may also be covered by the field coating. To ensure high peel resistance roughen the epoxy resin or adhesive using a manual wire brush. Remove any traces of oil and grease using a suitable solvent.

When coating bare steel pipes take special care to ensure that no mill scale is present on the pipe surface. Any mill scale must be blasted to Sa 2.5 in accordance with DIN EN ISO 8501-1.

Clean about 100 mm of the factory coating adjacent to the cutback area and roughen it manually using a wire brush.

Before priming a pre-coating with a zinc dust paint has to be applied up to 150 mm under to field coating.

**Polycor-Primer KIII** will be applied with a brush or roller after the drying of the zinc dust paint. 100 mm of the factory coating must be included. Prior to the application of the tape the **Polycor-Primer KIII** must be completely dry. Drying with a propane torch is prohibited.

Ensure the area to be coated is preheated sufficiently! 2 Layers of **Kebu Polycor Tape GW/KF** will be applied edge to edge starting at the factory coating. The junction must be smoothen with a hot spatula.

2 additional layers must be applied edge to edge starting 100 mm on the factory coating and the edge region must be smoothen with a hot spatula.

Heat the segments using a propane torch until about 0.5 up to 1 mm of the bitumen layer is fluid. The separation foil must be melted thoroughly before applying a second layer.

The tape layers are applied staircase-shaped, that a straight slant is formed after the smoothening of the edges.

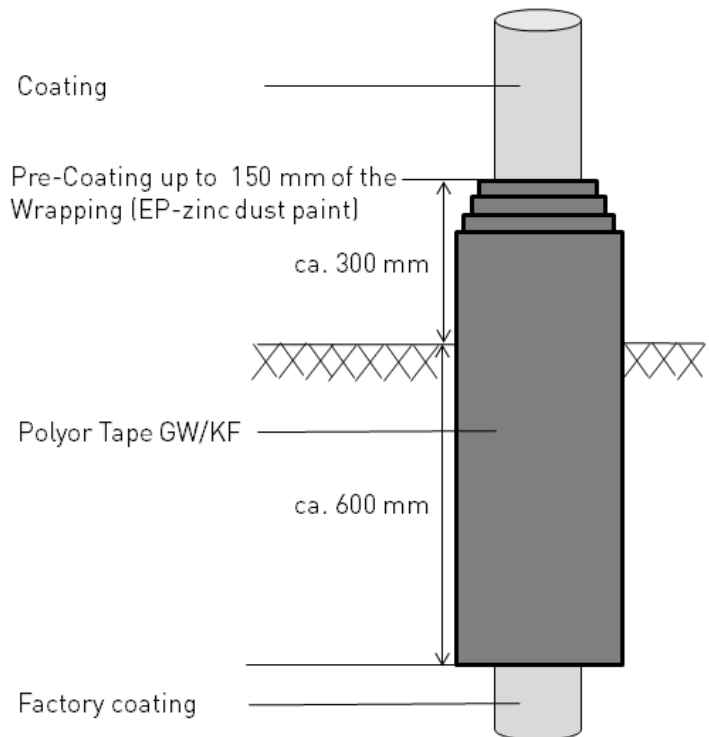

The information given in this publication is based on our knowledge and experience. The hints and instructions for use given therein have been compiled to the best of our knowledge on the basis of our tests and experience. Best results will be obtained if our products are used in a proper and expert way. Any protected rights and existing laws and regulations must be complied with the recipient. In all other respects our general terms and conditions shall apply.  
-- Rev.: 00\_19.07.2019 --